



Technical comercial data ref.

Serie MASTER NOVA

CAPO011604 30-11-22
Lid design especially configured for thermosealed buckets

TECHNICAL DATA:

Material: Polypropylene copolymer of first quality, suitable for contact with food according to current regulations.

Colours: White standard. Consult for other colours.

Useful Volume: 16 litres

Volume to the edge: 19 litres

Weight of the bucket: 600 g. approx.

Weight of the lid: 171 g. approx.

Weight of the handle (plastic): 35 g. approx.

Total Weight: 806 g. approx.

Decorative surface flat inks: 190 x 911 mm (height x perimeter)

Design surface photographic finish: 210 x 930 mm (height x perimeter)



MEASUREMENTS:

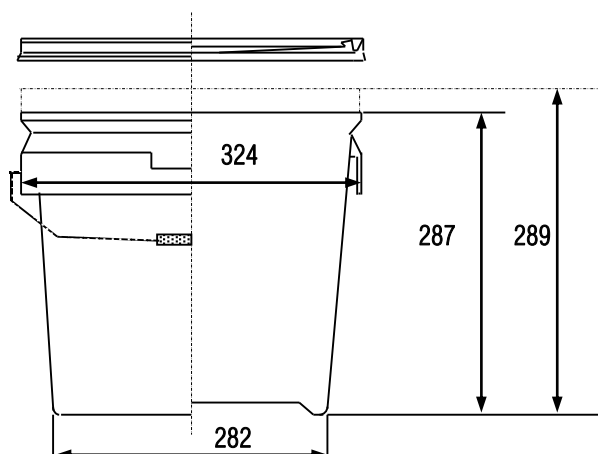

Measurements in millimetres

GROUPING OF TRASPORT:

Buckets: 360 buckets per pallet
Pallet dimensions: 1325 x 1000 x 2250 (see drawing)

Lids: 50 lids per box, this serves as a packaging of transportation

Box dimensions: 335 x 335 x 1020

